

THE GATLING MARX GENERATOR SYSTEM

J. R. Mayes, W. J. Carey, W. C. Nunnally [1], L. Altgilbers [2]

Applied Physical Electronics, L.C.
Austin, Texas 78734

Abstract

Traditional multi-pulse systems require multiple uncoupled sources, each driving a unique load. A phased array system, for example, may use multiple sources, each with its own antenna element, to radiate multiple pulses or a steered single pulse to a target. However, the Injection Wave Generator (IWG) has brought the concept of coupling multiple sources with a single load transmission line. Thus, multiple sources may be used to drive a single load element.

In the case of a radar source, the overall volume of the system may be drastically reduced with only one antenna. This paper discusses a Marx generator-based IWG system designed to deliver multiple high voltage pulses to a single load. The pulse magnitudes are on the order of several hundred kV, and with a pulse separation of 10^3 's of nanoseconds. The system is described with an emphasis on the results of the experimental system. Radiation results, with the Gatling system driving a single TEM horn antenna are presented and discussed.

I. INTRODUCTION

Marx generators are finding an increasingly important role in modern radar systems as well as electronic warfare systems. These generators offer compact geometries while delivering extreme voltage levels of several hundred kV. Furthermore, with careful design, these devices can deliver pulses with risetimes of less than 200 ps and pulsewidths of only a few nanoseconds.

Two enabling technologies make a Gatling-styled pulse generator a practical technology. The first is offered by the Injection Wave Generator, which demonstrates the ability to add multiple electrical pulses from unique sources onto a common output transmission line. The second, the wave-erection Marx generator offers extremely fast rising, high voltage, short duration pulses. It is from these two technologies that the Gatling system was derived, and demonstrated.

II. BACKGROUND

A. The Injection Wave Generator

The Injection Wave Generator [3] (IWG) uses multiple parallel energy sources to produce an RF burst into a single transmission line directly from DC, as shown in

Figure 1. Work on the IWG has been limited to a photoconductive switch-based system.

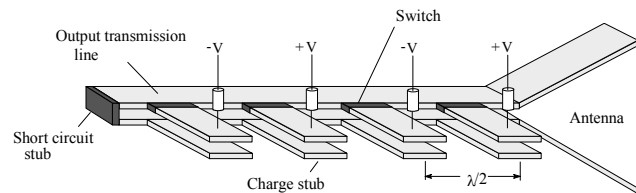

Figure 1. The Injection Wave Generator.

An illustration of pulse generation and pulse propagation is shown in Figure 2. At each injection point, two pulses are generated immediately following switch closure: a forward wave moving toward the load, and a rearward wave moving toward the short circuit stub at the opposite end of the line, as shown in Figure 2 a). The rearward moving wave is negatively reflected by the short circuit stub and follows the forward moving wave to the matched load after a time delay defined by the two-way transit time from the switch to the short as illustrated in Figure 2 b).

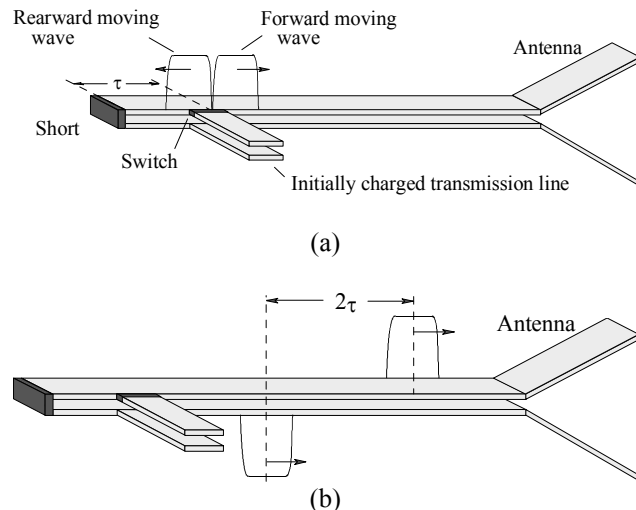

Figure 2. Propagation and spatial dependence of the injected waves, (a) launched waves, (b) resulting propagation.

In essence, each charge section delivers a full cycle of energy. In general, however, the two halves of the cycle are separated by the two-way transit time. Only the injection point closest to the short-circuit stub produces a

cohesive cycle of energy. Subsequent charge sections simply add pulses to the front of the forward moving wave and to the end of the rearward moving wave.

B. The Wave Erection Marx Generator

The most efficient, compact and economical method of generating a repetitive, large magnitude, electromagnetic impulse is the wave erection of a spark gap-switched Marx circuit. Wave erection is necessary to obtain the fast voltage risetimes from the Marx circuit that generates the ultra-wideband of frequencies necessary for high resolution radar or the interdiction of flight controls and computer memories for electronic warfare.

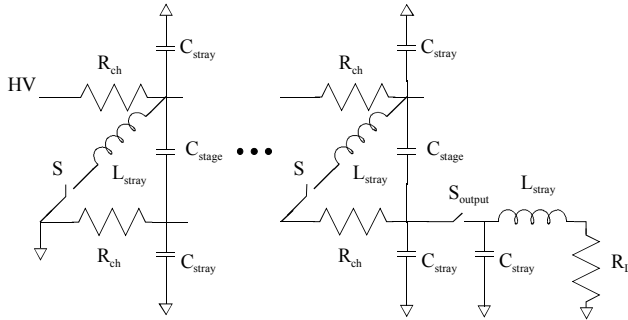

Figure 3. The Wave-Erection Marx Generator.

The conventional Marx circuit, illustrated in Figure 3, charges capacitors in parallel through resistors, and then switches the capacitors, using spark gap switches, in series to add the individual capacitor voltages at the output terminals. This approach multiplies the charge voltage by the number of stages to yield a large output voltage. Proper design of the stray capacitance and the inter-stage capacitance, in concert with coupling the spark gaps via ultra-violet energy, results in a sub-ns risetime for output voltages of several hundred kV at moderate per pulse energies.

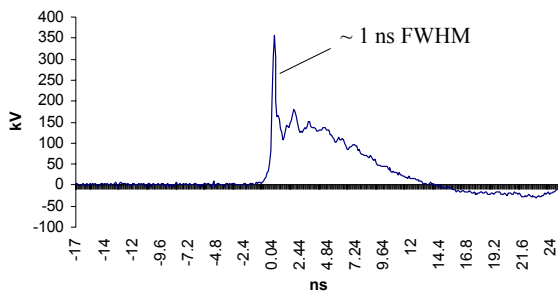

Figure 4. A typical output pulse from the APELC Marx generator.

III. EXPERIMENTAL ARRANGEMENT

A. Experimental Marx Generator

Three generators were identically fabricated for this effort. Each generator consisted of 17 stages, with a

charging voltage of 30 kV. Although the generator in this configuration typically produces the waveform of Figure 4, these generators were instead operated at 150 kV such as to limit breakdown problems in the system.

Each generator is very compact, with a diameter of 76 mm and a length of 1 m. These generators deliver only 3.8 J, and at moderate repetition rates, and they may be powered with commercial batteries and dc/dc converters.

B. The Gatling System

The Gatling Marx Generator system takes the IWG concept and replaces the transmission line stubs with wave erection Marx generators. Each generator is essentially isolated from the common transmission line with magnetic material, as illustrated in Figure 5. Also, all of the injection points are located at a common point on the output transmission line.

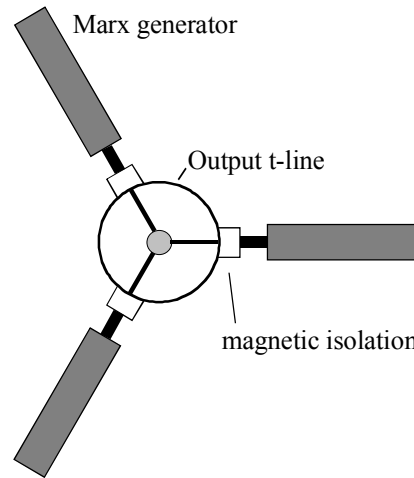

Figure 5. Generator interconnection with output transmission line

Essentially when the system is fired, each generator delivers a pulse onto the common transmission line. As described in the *Injection Wave Generator* section of this paper, the forward-moving wave proceeds directly to the load and the rearward-moving wave is launched toward the short of the common transmission line. However, upon reflection, most of the energy of the rearward-moving wave is absorbed back into the magnetic material, resetting the ferrite to its original state.

The final experimental arrangement is shown in Figure 6. This figure shows two generators connected to the common output transmission line at a common launching point. All three of the generators are triggered by a single trigger circuit, which is based on a krytron-stack configuration. The coaxial lines connecting each of the generators to the trigger circuit are unique in length, thus offering delays between the pulses delivered to the output line. A capacitive voltage divider is located at the output of one of the Marx generators and is used as a trigger signal for the SCD5000. A second capacitive

probe is placed at the output of the Gatling system to monitor the generated signal.

Since the custom output transmission line may be characterized as having a large diameter, a coaxial taper guides the Gatling signal onto a long section of RG-220.

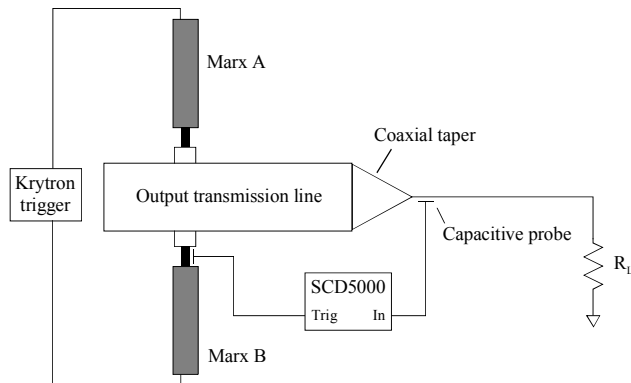

Figure 6. Experimental arrangement.

C. Test Range

The Gatling system was to be tested for its radiative performance, designed to demonstrate the ability to radiate closely-spaced, high voltage, UWB pulses. A crude TEM horn antenna was fabricated for this purpose, with minimal attention placed on efficiency and performance. A second antenna, purchased from EMCO (model 3106) was a ridge horn antenna placed 100 m from the source antenna, as shown in Figure 7. Unfortunately, little attention was toward ground-bounce noise, as each of the antennas was placed approximately 3 m above ground level.

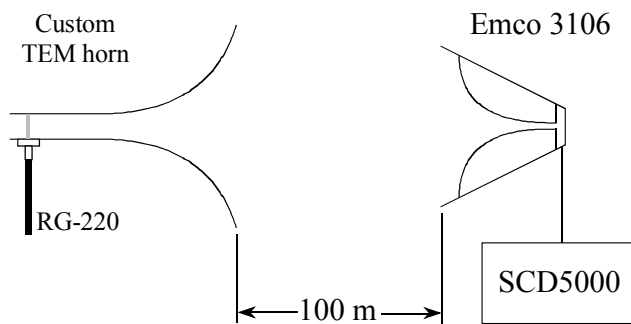

Figure 7. Radiation measurements setup.

IV. EXPERIMENTAL RESULTS

Initial measurements on the system were made in the laboratory with the capacitive probes. As shown in Figure 8, three distinct pulses are launched from the Gatling system. Each pulse has an approximate magnitude of 125 kV and has a large degree of noise associated with its signal, some of which may be attributed to the capacitive probe differentiating the 15 ns pulse. Additional noise problems also lie in impedance

mismatches of the system. For this purpose, the triggering of Marx C was intentionally delayed to illustrate noise levels.

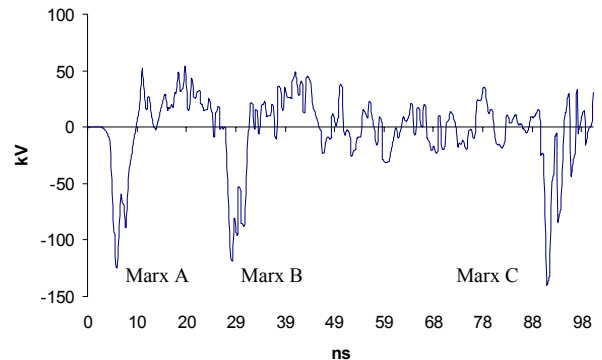

Figure 8. Output waveform of the Gatling system measured with a capacitive probe.

Moving to the field, the Gatling system was tested for radiative abilities. Again, as shown in Figure 9, three distinct pulses were generated by the Gatling system and successfully launched by the TEM horn antenna. Field strength measurements were not made, since a calibrated probe was not available.

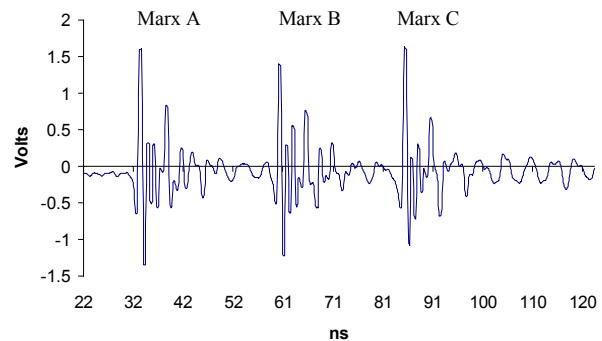

Figure 9. Radiative results from the Gatling system.

V. Conclusion

This paper presented the results of the Gatling Marx Generator system. This effort successfully demonstrated the ability to launch multiple high voltage pulses from unique sources onto a common transmission line. Thus, only one load element is required.

Three pulses, each of an approximate magnitude of 125 kV and separated by 30 ns were realized at the load. This same signal was also delivered to a TEM horn antenna, resulting in a three pulse burst signal being received by a second TEM horn antenna 100 m from the source.

Unfortunately, the Gatling signal is plagued with excessive noise, which must be minimized for the Gatling system to become a practical radar source. This will be the basis for future efforts. Additional efforts will also

focus on increasing the peak voltage to more interesting levels.

VI. References

- [1] W.C. Nunnally, The University of Missouri-Columbia, Columbia, Missouri, 65211.
- [2] L. Altgilbers, U.S. Army Space and Missile Defense Command, Huntsville, Alabama 35807-3801.
- [3] Mayes, *The Injection Wave Generator, Dissertation*, The University of Missouri-Columbia, 1998.