

# DEVELOPMENT OF A SEQUENTIALLY SWITCHED MARX GENERATOR FOR HPM LOADS

J.R. Mayes<sup>ξ</sup> and C.W. Hatfield

Applied Physical Electronics, L.C., PO Box 341149  
Austin, Texas, USA

## Abstract

Relativistic Magentrons prefer trapezoidal-shaped, high voltage pulses, as opposed to the double exponential waveshape characteristic of a Marx generator. Traditional approaches use intermediate Pulse Forming Lines (PFNs) or stacked Blumleins to create the desired pulse shape. Marx generator-driven PFNs are unacceptable, due to their size and additional overhead. Stacked Blumleins are very difficult to switch, when a large number of lines are required, which results in small line impedances. Applied Physical Electronics L.C. is developing a novel Marx generator topology that results in a rectangular waveshape, without additional pulse conditioning hardware. The topology is based on a multi-generator design. Each generator is sequentially switched to the common load, so as to simulate a rectangular waveshape. In essence, the desired rectangular pulse shape is built temporally, and the capacitance of the load can be designed to reduce the ripple in the load waveform. Each generator can be uniquely charged and triggered, resulting in a programmable, high voltage waveform generator. The generator is described for its geometry. Simulation and experimental results are provided.

## I. INTRODUCTION

Pulsed power generators designed for generating High Power Microwaves have generally been limited to resonant transformers, and pulse forming networks driven by Marx generators. Each method offers advantages and disadvantages; yet, both methods deliver high voltages with large amounts of energy. The disadvantages of the transformer-based method are its large volume, transformer oil requirements, and delivery of slow rise time pulses. The Marx generator-based method is typically hindered by requirements for large numbers of components, and the difficulty in designing the Marx circuit to obtain trapezoidal wave shapes. Additionally, each method is binary in operation—they either work or they do not work; there is no graceful failure in either design.

This paper describes a novel Marx generator-based concept that overcomes these disadvantages. The part count issue is addressed by a modular design, and the

wave shaping problem is solved via sequential pulse delivery approach commonly used in railgun power supplies. Furthermore, since the design is based on a parallel generator topology, the system offers temporal agility, impedance agility and graceful failure. The basic principles are presented and supported by simulations. Experimental results are discussed.

## II. BACKGROUND

The fundamental concept is centered on the sequential delivery of high voltage pulses. As shown in Figure 1,  $N$  pulses can be delivered sequentially to the load, with the load integrating the pulses for a relatively smooth waveform. A crowbar switch can be added so as to “clip” the trailing edge of the last pulse to remove undesired energy from the High Power Microwave (HPM) load’s cathode.

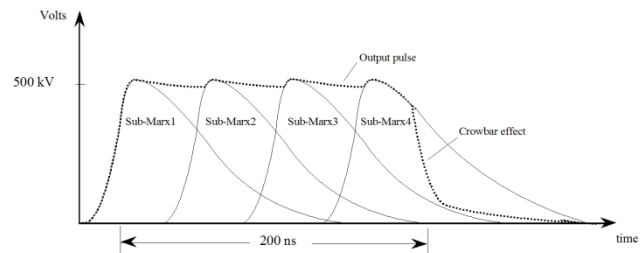

**Figure 1.** Illustration of Sequentially Delivered High Voltage Pulses to a Common Load

The proposed generator topology is illustrated in Figure 2. Parallel Marx generators are contained in a common housing structure such that the generators share only the ground plane and the common output connection; otherwise, the generators are completely unique in their operation, including charge and trigger. Each generator is also connected to the common output, via saturable inductive elements. These elements (switches), which are simply ferrite-based inductors, are forced into a conductive state, or saturated, by their corresponding driving generator. However, with a reversal of current, as posed by a neighboring Marx firing, the switches pull out of saturation and into a high impedance state, thereby isolating its owning Marx generator.

<sup>ξ</sup> email: mayes@apelc.com

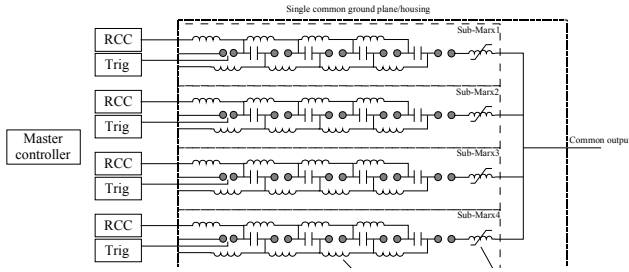

**Figure 2.** Basic Schematic for the Sequentially Switched Marx Generator System

Employing unique power supplies, i.e. one each for each generator, and uncoupling common triggers, leads to graceful system failure and overcomes a leading problem in traditional pulse generator designs. For example, should sub-Marx 1, of  $n$ -sub Marx generators, break down due to component failure, the system can continue to operate with the remaining  $n-1$  sub-Marx generators with degraded, yet functional performance.

The unique trigger system of each sub-generator enables the system to achieve temporal pulse agility and impedance agility. Simultaneously triggering all generators leads to a low source impedance, i.e. less than  $10 \Omega$ . Staggered triggering, a technique commonly used in railgun power supplies, provides a means to temporally separate pulses for sequential delivery in order to simulate a flatter pulse shape as illustrated in Figure 1.

### III. DESIGN AND SIMULATION

The ultimate design goal of the sequentially-switched Marx generator is to deliver a 500 kV flatter pulse onto a 40 – 50 Ohm load, with a 200 ns duration. Table 1 describes the proposed generator (and sub generators). A per pulse energy of 2000 J is chosen to ensure that a 200 ns pulse duration is achieved. Divided between 8 Marx generators, the energy per generator becomes 250 J. The 1 MV erected voltage is divided by the charge voltage of 50 kV, which results in 20 stages. The stage capacitance is resolved from the per generator energy, the charge voltage and the number of stages, which is calculated to be 10 nF per stage. To achieve a per generator impedance of  $40 \Omega$ , a series inductance of 800 nH will be required.

PSpice model of Figure 4, expanded to include eight sub-Marx generators, and employing the parameters defined in Table 1, simulations were performed to verify the proposed performance. The simulation, as expected, suggests that the proposed design will result in a flatter pulse characterized by a 570 kV amplitude, 40 kV ripple (or less than 10%), and an approximate 500 – 600 ns decay, as shown in Figure 3. Incorporating the simple crowbar switch, the tail is dramatically reduced to less than 13% of the magnitude, with inductive ring present, as illustrated in the PSpice output waveform of Figure 4.

**Table 1.** Proposed Characteristics of the Sequentially Switched Marx Generator System

Parameter	Description	Value	Unit
<b>Kirtland definitions</b>			
$V_{load}$	Load voltage	500	kV
$Z_{load}$	Load impedance	40	Ohm
$T_{pulse}$	Pulse duration	200	ns
<b>System characteristics</b>			
$P_{peak}$	Peak power	6.25	GW
$E_{pulse}$	Energy per pulse	1250	J
$E_{pulse,loss}$	Energy per pulse, allowing for loss	2000	J
$N_{sub-marx}$	Number of sub Marx generators	8	
$E_{Sub-marx}$	Energy stored per Marx	250	J
$D$	Diameter	12-15	inch
$L$	Length	36	inch
<b>Sub-Marx generator characteristics</b>			
$V_{ch}$	Charge voltage	50	kV
$N$	Number of Marx stages	20	
$Z_{marx}$	Source impedance	40	Ohm
$C_{erect}$	Erected capacitance	500	pF
$C_{stage}$	Stage capacitance	10	nF
$L_{series}$	Approximate series inductance	800	nH
<b>Single power supply configuration</b>			
$P_{ave}$	Available average power	60	kJ/s
$TRR_{max}$	Maximum repetition rate	30	pps
<b>Parallel power supply configuration</b>			
$P_{ave/unit}$	Average power per power supply	10	kJ/s
$N_{unit}$	Number of parallel power supplies	8	
$TRR_{max}$	Maximum repetition rate	40	pps

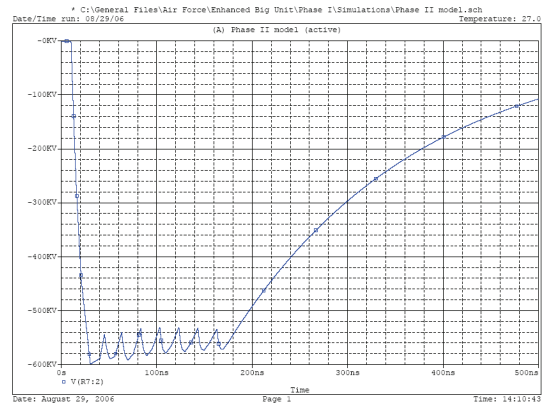
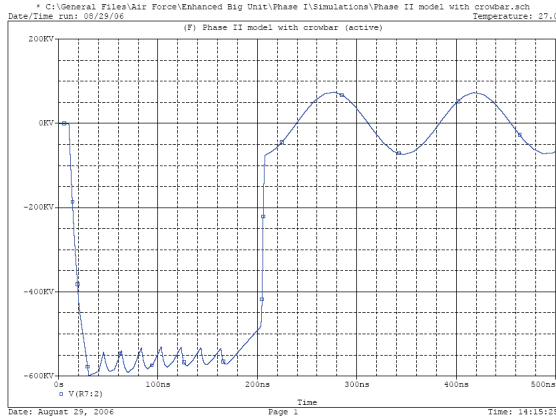

**Figure 3.** PSpice Generated Output Waveform Illustrating the Summation of the Time Separated Marx Generator Pulses Delivered to a Single Load

#### *Proof of Principle Demonstration*

A 4-element prototype is designed and simulated to determine the feasibility of the proposed design. The prototype source is designed with four, 4-stage generators, with a maximum charge voltage of 40 kV. The results of the simple simulation are provided. The circuit is first simulated with each generator dumping its energy into a unique load. As illustrated in Figure 5, the voltage pulses are temporally separated by approximately 30 ns. Next, the generators are configured to fire into a common load, with each generator isolated from the load with a 1  $\mu$ H inductor. A flatter pulse is demonstrated; however, the pulse is also characterized by a lengthy RC decay lasting several 100 ns. The simulation results shown in Figure 7

illustrate the case in which the last Marx generator is charged with an opposite polarity. While the RC decay remains evident, its magnitude is reduced by approximately 70%.



**Figure 4.** PSpice Generated Output Waveform Illustrating the Addition of a Crowbar Element

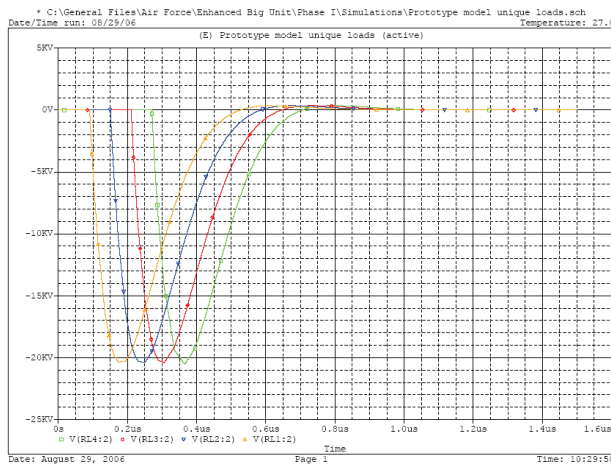

**Figure 5.** Sample Simulation Waveform with Each Generator Driving its Own Resistive Load

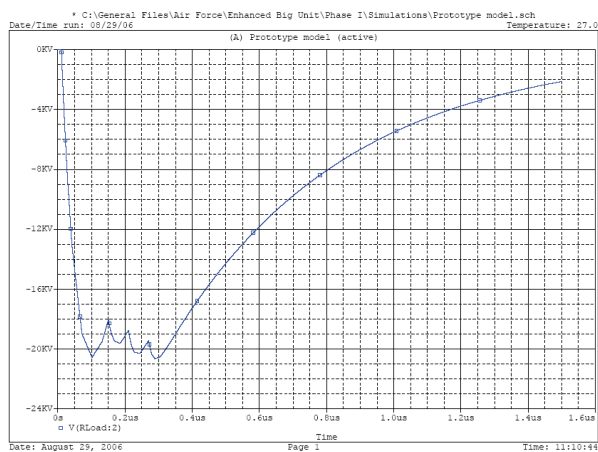

**Figure 6.** Sample Simulated Output Waveform with the Four Generators Firing into a Common Load

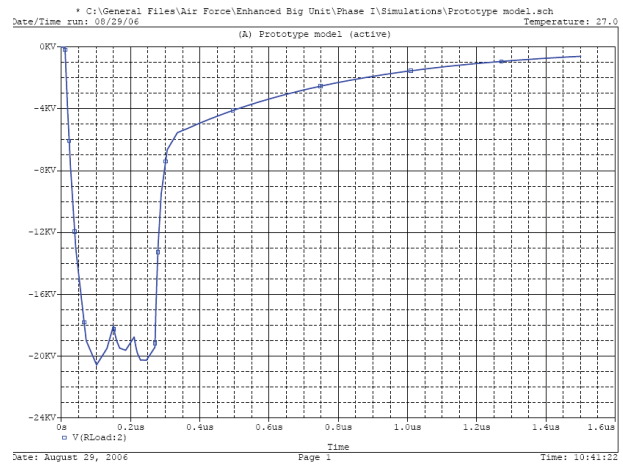
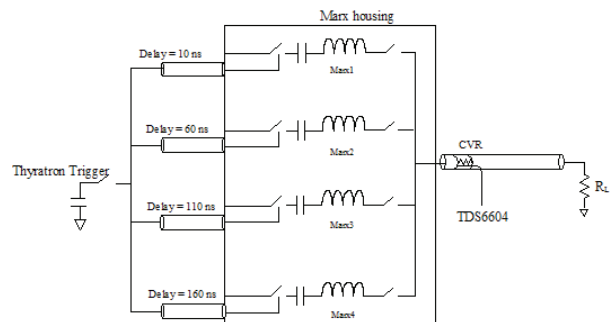

**Figure 7.** Sample Simulated Output Waveform with the Final Marx Generator Being Charged with an Opposite Charge Polarity

#### IV. EXPERIMENTAL RESULTS

A prototype source is built and tested. A common power supply is used, as well as a common high voltage trigger source, with varying lengths of cable so as to temporally separate the triggering of the Marx generators, as illustrated in Figure 8. Figure 9 provides the baseline shot, in which the Marx generators are charged to 30 kV, and are isolated from the load with a 1.3  $\mu\text{H}$  air core inductor. The generators are well matched to the 50  $\Omega$  cable load, and a less than 25% ripple on the output pulse is observed. Next, the isolation inductance was increased over several values. Ultimately, an isolation inductance of 2.3  $\mu\text{H}$  proved to be the best fit, giving a voltage efficiency of 50% and a ripple of less than 10%, as shown in measurement provided in Figure 10.

The basic crowbar configuration, the tailbiter switch, was not included in the experimental hardware. However, the Marx-based crowbar, in which the final Marx generator is charged with an opposite polarity charge, was tested. A test waveform is provided in Figure 11. The three primary pulses are evident, and the fourth pulse obviously crowbars the main pulse. In reference to Figure 9, which was characterized by a 1  $\mu\text{s}$  tail, the Marx/crowbar configuration results in a tail of less than 600 ns for a 40% reduction in fall time.



**Figure 8.** Schematic of the Experimental System

## V. SUMMARY

A sequentially switched, multi-Marx generator source has been proposed and demonstrated for delivering rectangular-shape high voltage pulses to source high powered microwave diodes. The Marx generators are commonly housed and are configured to drive a common load. The ultimate design was discussed and support by simulation. A simple four Marx generator prototype source was designed, simulated, fabricated and tested to demonstrate the feasibility of the source. Rectangular output pulses of 20 kV were demonstrated, and were characterized by ripples of less than 20%. The concept of charging the final Marx generator with an opposite charge voltage, and for the purpose of crow barring the output pulse, was also successfully demonstrated.

While the desired pulse shapes were achieved, the system was difficult to reliably operate. In brief, the Marx generators must be properly isolated from each other, so that the triggering of the first Marx generator does not cause the remaining generators to self break. This is accomplished by minimizing the Marx-to-Marx stray capacitance, while increasing the Marx-to-ground stray capacitance. Strong, energetic trigger pulses also aide in the performance, allowing the individual Marx generators to operate further away from the point of self break.

Future efforts will focus on the development of the full scale system.

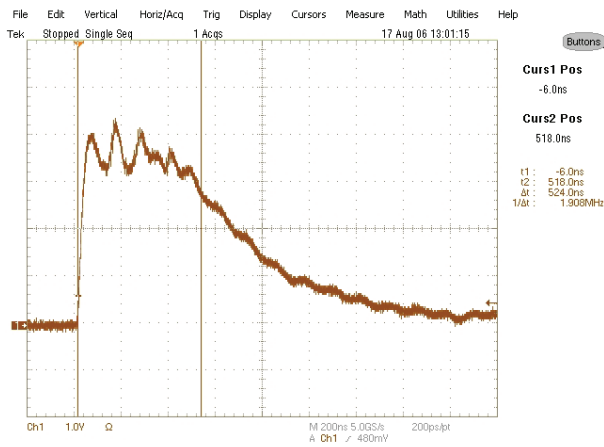

**Figure 9.** Sample Output Waveform with 1.3  $\mu\text{H}$  Isolation Inductors

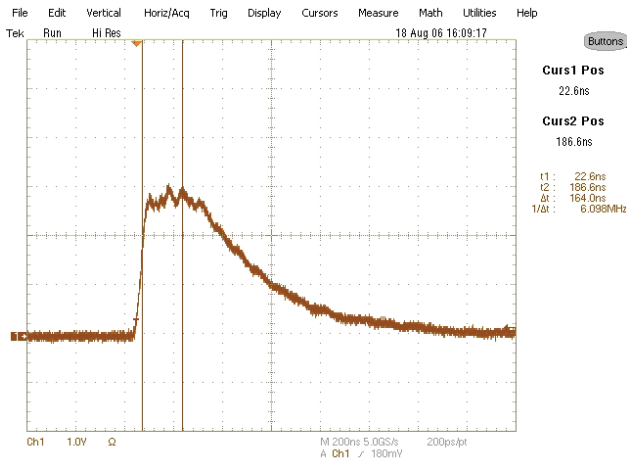

**Figure 10.** Sample Output Waveform with 2.3  $\mu\text{H}$  Isolation Inductors

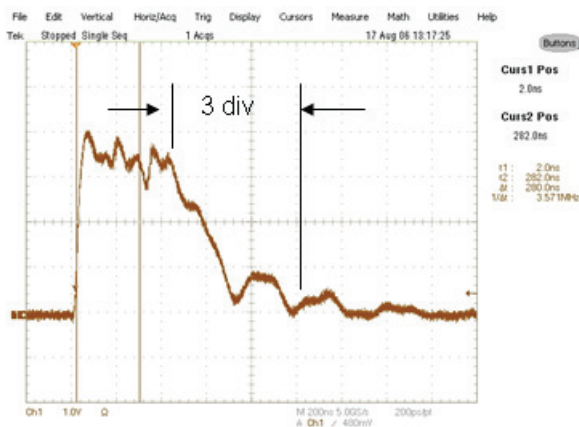

**Figure 11.** Sample Output Waveform with the Last Marx Generator Charged with an Opposite Polarity Charge for Crow Barring the Main Pulse