

# A MARX GENERATOR DRIVEN IMPULSE RADIATING ANTENNA

T. A. Holt<sup>✉</sup>, M. G. Mayes, M. B. Lara, J. R. Mayes  
*Applied Physical Electronics L C , PO Box 341149  
Austin, TX, USA*

## Abstract

APELC has developed an Impulse Radiating Antenna (IRA) that consists of a TEM-horn-fed parabolic reflector that is directly driven by a 22-J, 400-kV Marx generator. The system is based on standard Marx generator designs offered by APELC. The Marx generator output couples directly to the TEM horn via a transition from a coaxial geometry that approximates a standard coaxial-to-parallel plate transition. Primary design considerations that facilitate achievement of high instantaneous radiated power include appropriate Marx generator rise time, transition design, and TEM horn focal point positioning. Data collected over the course of the system design is presented.

## I. BACKGROUND

Impulse Radiating Antennas (IRAs) have been extensively tested and reported on in open literature [1],[2]. Systems with direct feed schemes similar to that proposed herein, however, have not been reported

extensively. The advantage of the APELC IRA system is that the Marx generator driving the IRA is directly connected to the RF feed which eliminates the need for a low-impedance cable between the Marx and RF feed and also reduces the need for a complicated impedance-matching balun. The disadvantage of the proposed system is the aperture blockage caused by the Marx and Marx support structure.

## II. SYSTEM DESIGN

The APELC impulse radiating antenna, shown in Figure 1, is comprised of a MG10-3C-940PF Marx generator, a 6-ft parabolic reflector, a custom built support frame, a transparent TEM horn, and a TEM horn feed section. The Marx generator directly drives an inline balun in a configuration referred to as an unbalanced feed which then flares out to form a TEM horn that terminates on the perimeter of the parabolic reflector.

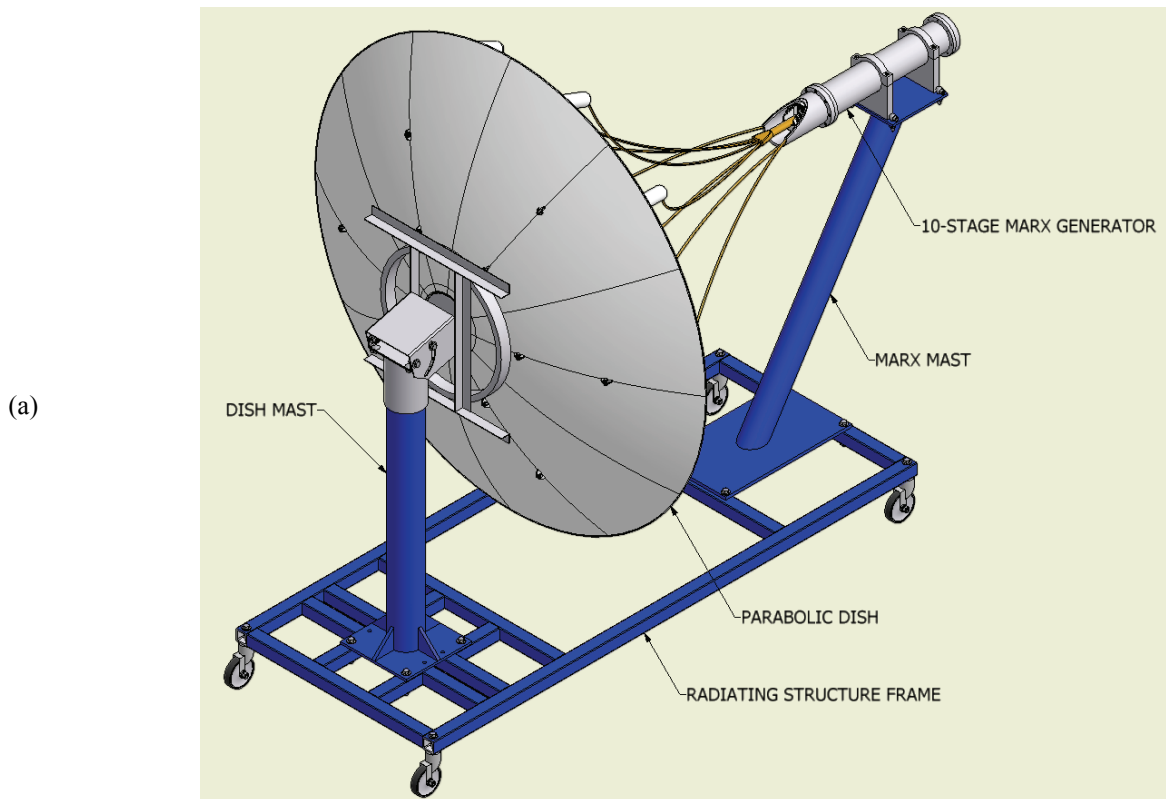

<sup>✉</sup>email: [tholt@apelc.com](mailto:tholt@apelc.com)

(b)

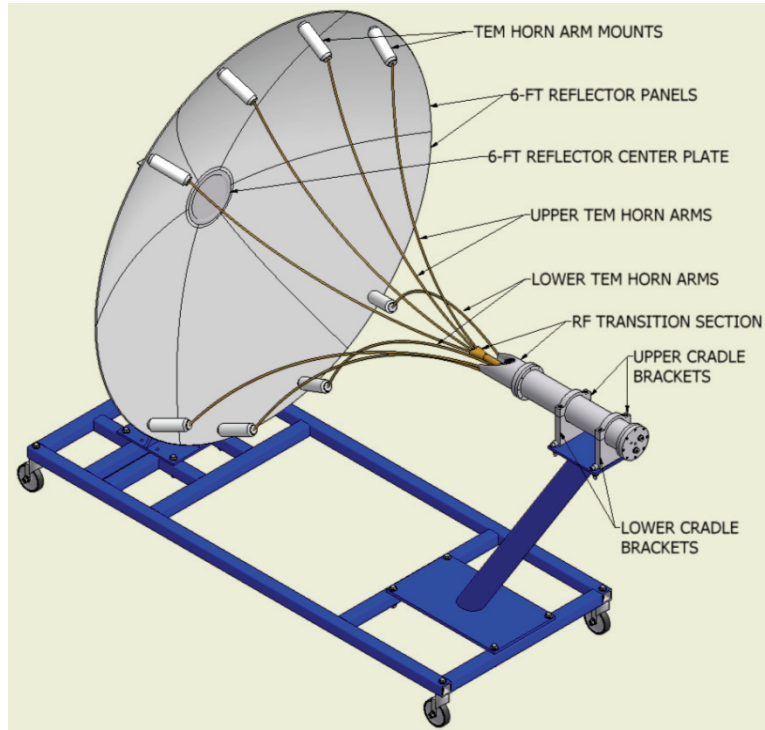

**Figure 1.** (a) Major components of the APELC 6-ft IRA. (b) Major components comprising the RF transition section, the parabolic reflector, and the Marx generator mounting hardware.

#### A. Marx Generator

The Marx generator used in the system is a slight modification of the APELC MG15-3C-940PF, reported in [3], the only difference being that five stages were removed from the generator resulting in a lower impedance, 10-stage, Marx generator capable of a peak erected voltage of 400 kV. The electrical specifications of the MG10-3C-940PF used as the source for the IRA system are listed in Table 1. The stages that were removed allowed for the accommodation of a peaking circuit that was placed in-line between the Marx generator output and the TEM horn feed section.

**Table 1.** Electrical Specifications of the MG10-3C-940PF.

Parameter	Value	units
Number of stages	10	-
Peak erected voltage	400	kV
Maximum charge voltage	40	kV
Maximum energy per pulse	22	J
Capacitance per stage	2.82	nF
Erected capacitance	282	pF
Series inductance	250	nH
Source impedance	30	Ohms

#### B. RF Specifications

An inline balun is used to gradually transition from the coaxial Marx generator geometry to the parallel plate feed required for the TEM horn that sources the parabolic reflector. The gradual taper is a necessity in order to reduce geometric discontinuities that can cause impedance mismatches and consequent reflections of propagating waves. Abrupt geometric discontinuities ultimately lead to an inefficient RF system.

A traditional TEM horn could not be used to source the parabolic dish along the axis of the parabolic reflector due to the large aperture area (and subsequent aperture blockage) required to radiate the frequencies of interest. A semi-transparent TEM horn was used to source the reflector and was constructed using  $\frac{1}{4}$ " brass rods to guide the propagating wave onto the reflector.

The parabolic reflector has a diameter of 180 cm and a focal distance of 68.2 cm yielding an F/D ratio of 0.38. Due to the amorphous nature of the transition from the coaxial Marx generator geometry to the semi-transparent TEM horn, a precise definition of the phase center of the source was difficult. Consequently, the optimal position of the Marx with respect to the parabolic dish was determined by experiment and simulation rather than by analysis. Experiments with the system demonstrated that very small deviations in the position of the Marx with respect to the parabolic reflector significantly affected the radiated field amplitude and pulse shape. Deviations as small as  $\pm 0.200$ " from the optimal location resulted in a

10% decrease from peak radiated E-field. A deviation of  $\pm 0.500''$  resulted in a 13% decrease from peak radiated E-field. Similar results were found via simulation.

### C. System Specifications

The system's maximum volumetric footprint is approximately 10 ft. X 6 ft. X 7.75 ft and it is two-man portable and single-man operational. The system requires a source of compressed breathable dry air which is used in the Marx generator as an insulating gas at pressures below 250 psi.

As mentioned before, the frequency of radiation transmitted by the system is inversely proportional to the Marx output pulse rise time. The realized rise time would limit the highest frequency content radiated while the lower limit would be set by the parabolic reflector diameter, where frequencies lower than 100 MHz should not propagate well because the half-wavelength approaches the reflector diameter. Standard parabolic reflector design guidelines actually suggest sizing the reflector diameter at 3 wavelengths of the lowest frequency transmitted or received (a design guideline which was significantly stretched for the APELC IRA).

The system is capable of 50 Hz operation for 10 shot bursts. Subsequent revisions to the Marx geometry used in the IRA system have demonstrated repetition rates exceeding 200 Hz for burst lengths of several seconds. Additional system parameters are given in Table 2.

A conservative estimate of radiated electric field strength can be made using the radar equation and several simplifying assumptions. Assuming the Marx voltage of approximately 200 kV (i.e. 800 MW) couples to a 50-Ohm load and a system antenna gain of 10 dB, a conservative estimate of 490 kV/m normalized to a range of 1 meter can be derived as shown in Equation 1.

$$\sqrt{\frac{800\text{MW}}{4 * \pi * 1\text{m}} * 10\text{dB} * 377\Omega} = 490 \frac{\text{kV}}{\text{m}} \quad (1)$$

**Table 2.** APELC IRA system parameters.

Parameter	Value	units
Maximum system height	92	in
Maximum system width	72	in
Maximum system length	120	in
Focal Length of parabolic reflector	682	mm
Diameter of parabolic reflector	180	cm
Far field of system	5	m

## III. SYSTEM DESIGN AND PERFORMANCE

### A. Preliminary Experiments

The performance of the Marx generator was verified prior to its integration into the system. A cable load was fitted to the output of the generator and provided 30-ns one-way transit time isolation between the Marx generator and the load. Several different peaking circuit geometries were tested to reduce the Marx generator rise time, and all geometries tested used high-pressure dry breathable air as the insulating gas. The geometry implemented in the final system reduced the Marx rise time from 20% of peak amplitude to 80% from 2 ns to 520 ps, as shown in Figure 2.

A cable adapter section immediately follows the peaking circuit and serves two purposes. The first is to transition from the coaxial Marx generator to the coaxial cable (RG 220) used for transit time isolation. The second purpose served by the cable adapter is to create a pressure seal between the Marx pressure vessel and the outside environment. The mechanical and electrical aspects of the design contradict each other resulting in a small (~4 inches in length) high impedance section between the Marx output and the beginning of the coaxial cable. Consequently it is impossible to infer that the rise time of the pulse applied to the RF transition is the same as that shown in Figure 2 because the RF transition has a much more gradual impedance profile than the cable adapter section. Plans to re-engineer the cable adapter section and to incorporate diagnostics on the RF transition section are in place.

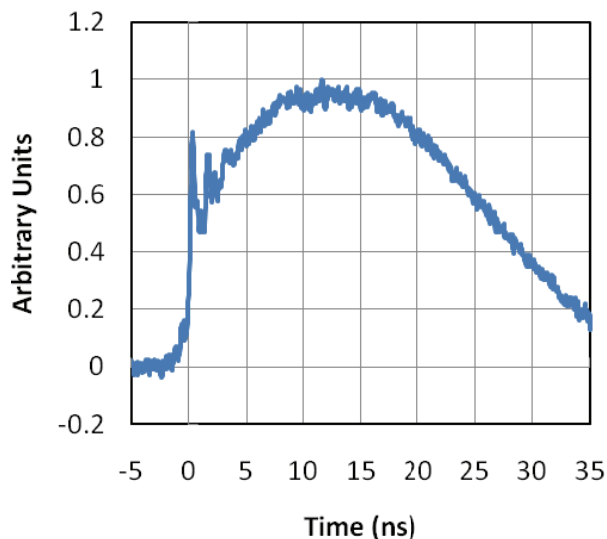
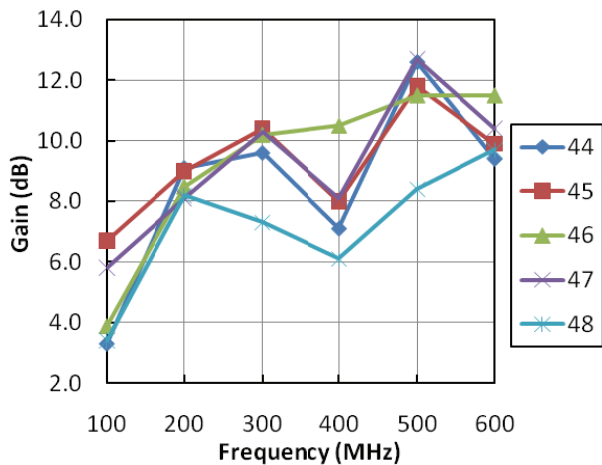

**Figure 2.** Example Marx generator waveform from testing with a cable load.

### B. Simulations of the System

Several simulations assisted the design of the system including an excursion of source position relative to the parabolic reflector to determine the dish focal point. The

abridged results of a focal point excursion are shown in Figure 3. The simulations were performed in CST Microwave Studio using solid models generated in SolidWorks. The simulation results demonstrated that system gain had the same sensitivity to relative source position as was observed in experiment and as is expected from standard antenna theory. While the observed behavior between simulation and experimental results were similar, the simulation space and resulting computational requirements were too extensive to precisely model the physical hardware created. Consequently, the optimal location of the Marx relative to the parabolic dish varied by several inches from the optimal distance of 46 inches found through simulation.



**Figure 3.** The dependence of relative position of Marx to parabolic reflector on system gain at several frequencies of interest. The legend indicates the relative distance between the source and the parabolic dish.

Following the determination of the optimal source to reflector separation distance, simulations of the RF

transition region, the semi-transparent TEM horn, and the parabolic reflector were performed. The RF transition was sourced by a unipolar impulse with a 600 ps rise time, a 15 ns fall time, and a total excitation interval of 40 ns to allow the simulated system to reach quiescence. The results of the simulations are shown in Figure 4. The top down view shown in Figure 4 (a) reveals a spherically diverging (i.e. convex) wavefront which is approximately conformal to the spherically converging (or concave) geometry of the parabolic reflector. The conformity of the spherically diverging wave with the reflector is expected because the RF transition is located at the optimal illumination distance. The side on view in Figure 4 (b) shows a somewhat broken spherical wavefront, likely caused by an asymmetrical unipolar excitation which results in behavior as a half TEM feed antenna. The side on view in Figure 4 (c) illustrates the far field gain in a linear scale and shows a 15 deg main lobe skew. Also note the side lobe emerging from the coax-to-transmission line transition.

### C. Low Voltage Diagnostics

TDR and VNA measurements were conducted on the system by replacing the Marx generator with a coaxial, constant impedance feed. The TDR measurements indicated that the impedance in the transition region (between the Marx generator output and the TEM horn arms) increased gradually from 60 to 90 Ohms. While a gradual impedance variation is desirable in order to match the 33-Ohm source impedance to free space impedance of 377 Ohms, it is unknown at this time if the impedance variation is optimal. Additional simulations are planned for the next revision of the APELCA IRA.

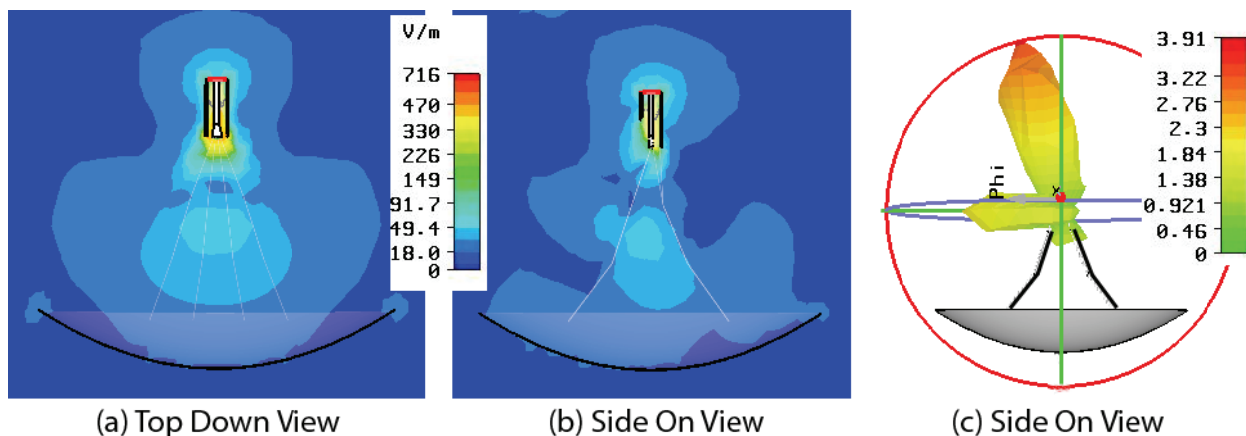

**Figure 4.** (a) A top down view of a near field cross-section of the IRA system excluding the Marx generator. (b) A side on view of a near field cross-section of the IRA system excluding the Marx generator. (c) Side on view of the far field gain from the IRA system.

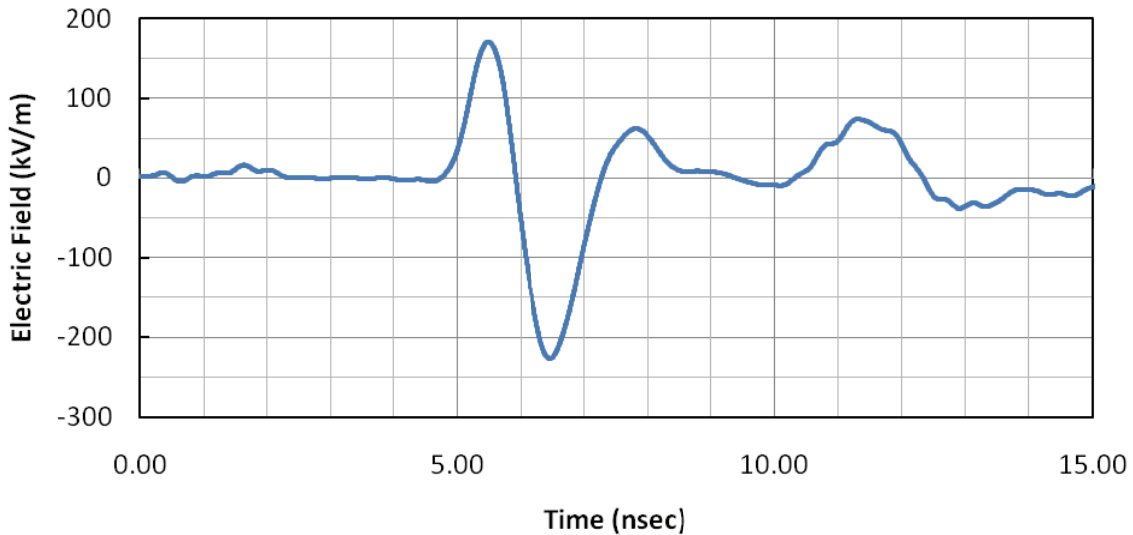

**Figure 5.** Experimentally measured radiated electric field normalized to a range of 1 meter.

VNA measurements indicated strong rejections around 360 MHz, 420 MHz, and 500 MHz, all of which are somewhat corroborated by the RF measurements presented in the subsequent section. Passbands were present between the aforementioned frequencies and it was also found that frequency components between 150 MHz and 220 MHz were not rejected.

**D. RF Measurements**

The entire system was tested following the low-voltage diagnostics and the cable load testing of the Marx generator. RF measurements were conducted on a 10-m

antenna range using an A. H. Systems double ridge guide horn (model SAS-570) as the receiving antenna.

The system was tested at a charge voltage of 40 kV and optimal peaking switch pressure. The resulting experimentally measured waveform is shown in Figure 5, and indicates a peak radiated electric field amplitude of approximately 220 kV/m when normalized to a distance of 1 meter. The spectral content of the radiated signal, shown in Figure 6 as a normalized FFT, shows a center frequency of 210 MHz and a 50% bandwidth of 80 MHz.

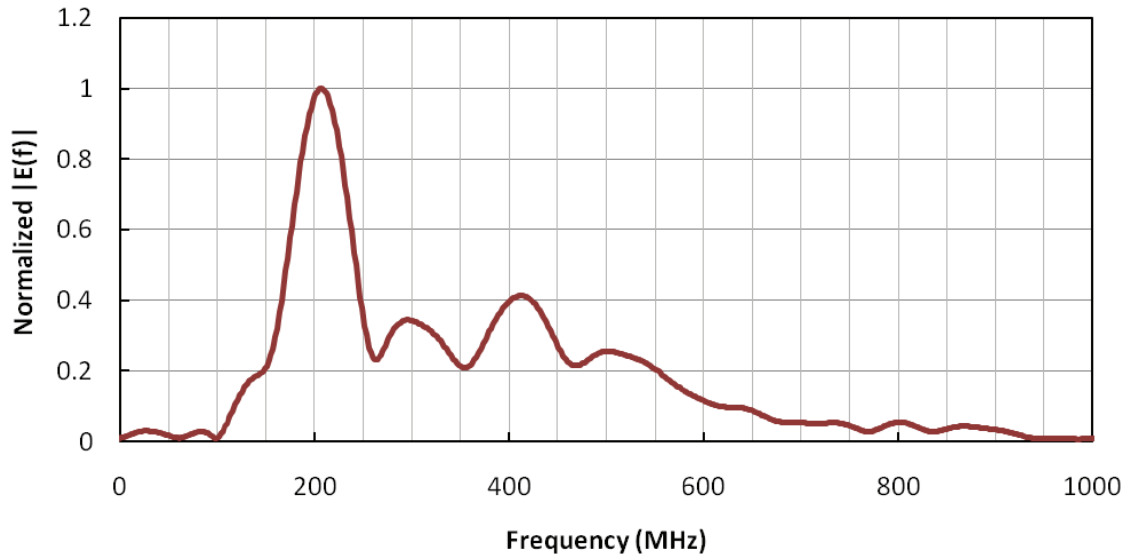

**Figure 6.** Spectral content of the radiated signal shown in Figure 5.

## IV. CONCLUSIONS

APELC has developed a Marx driven IRA capable of radiated electric field strengths in excess of 200 kV/m at a normalized range of 1 m and a center frequency of 210 MHz. The peak field strength produced by the system was nearly half of the value predicted by the radar equation. The system uses a coaxial-to-parallel plate transition section to mate a coaxial Marx generator to a semi-transparent TEM horn driven in an unbalanced mode. The first revision demonstrated the feasibility of a direct feed scheme even though the radiated field strength was far below the maximum predicted by the radar equation. Additional development on the feed scheme and the Marx generator peaking switch are either planned or presently underway.

## V. REFERENCES

- [1] I.D. Smith et al., "Design, Fabrication, and Testing of a Paraboloidal Reflector Antenna and Pulser System for Impulse-like Waveforms", in Tenth IEEE International Pulsed Power Conference, Digest of Technical Papers, Volume 1, 3-6 Jul 1995, pp.56 - 64.
- [2] E.G. Farr et al., "Multifunction Impulse Radiating Antennas: Theory and Experiment", in Ultra-Wideband Short-Pulse Electromagnetics 4, 1998, pp. 131 - 144.
- [3] C. Nunnally, et al., "Compact 200-Hz Pulse Repetition GW Marx Generator System," this conference.

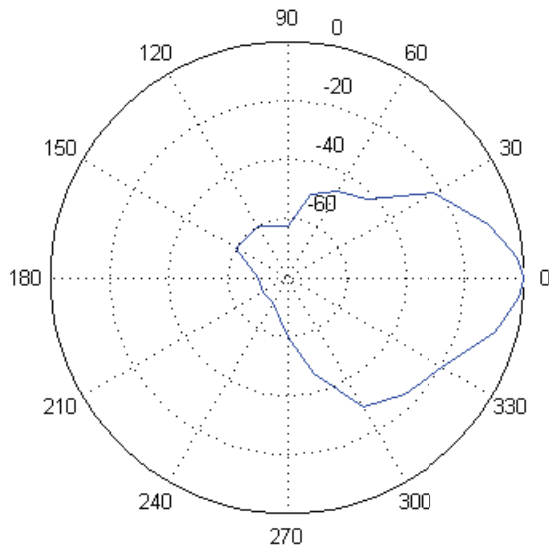

**Figure 7.** Measured antenna pattern for 6-ft Radiating Dish. The pattern given is a ratio of the measured field at each angular location (in degrees) to the maximum measured field in decibels.

The antenna pattern of the system, shown in Figure 7, was measured about the horizontal plane as illustrated in Figure 8. As is typical with any parabolic reflector antenna, the beam is narrow and tightly confined along the axis of the parabolic reflector. The half-power beamwidth of  $20^\circ$  is perhaps greater than would be expected from a system with a parabolic reflector. This could possibly be explained by the fact that the wavelength of the center frequency of the radiated signal is in the neighborhood of the diameter of the parabolic reflector, which might adversely affect the ability of the reflector to collimate the beam. The non-uniform illumination of the reflector as shown through simulation could also cause the broad antenna pattern. Additional study is planned prior to the next system revision.

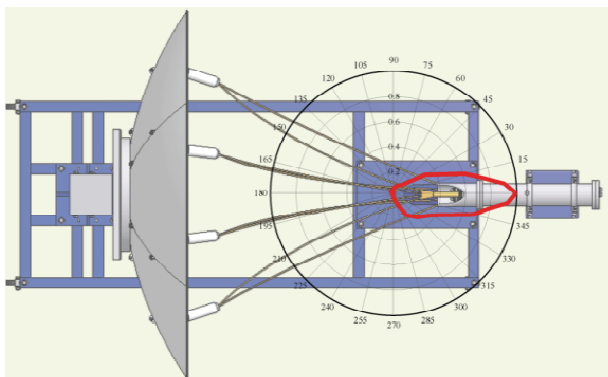

**Figure 8.** The orientation of the field pattern with respect to the system.